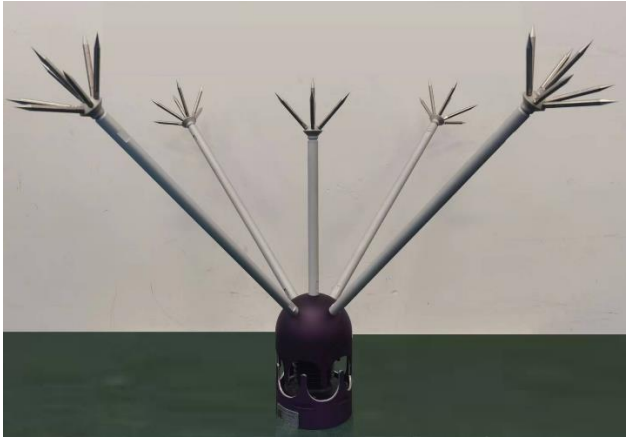

<b>Prüfbericht-Nr.:</b> <i>Test report no.:</i>	CN23W62W 001	<b>Auftrags-Nr.:</b> <i>Order no.:</i>	190146473	Seite 1 von 36 Page 1 of 36
<b>Kunden-Referenz-Nr.:</b> <i>Client reference no.:</i>	2493550	<b>Auftragsdatum:</b> <i>Order date:</i>	2023-03-16	
<b>Auftraggeber:</b> <i>Client:</i>	Beijing Keyichao Technology and Culture Development Co., Ltd. 207, Floor 2, Building 5, Yard 17, Jinsha West Street, Mentougou District, 102300 Beijing P.R. China			
<b>Prüfgegenstand:</b> <i>Test item:</i>	air-termination rods			
<b>Bezeichnung / Typ-Nr.:</b> <i>Identification / Type no.:</i>	KYC-LAT			
<b>Auftrags-Inhalt:</b> <i>Order content:</i>	AK certificate			
<b>Prüfgrundlage:</b> <i>Test specification:</i>	EN IEC 62561-2:2018			
<b>Wareneingangsdatum:</b> <i>Date of sample receipt:</i>	2023-03-14			
<b>Prüfmuster-Nr.:</b> <i>Test sample no.:</i>	Engineering sample			
<b>Prüfzeitraum:</b> <i>Testing period:</i>	2023-03-14 to 2023-03-17			
<b>Ort der Prüfung:</b> <i>Place of testing:</i>	See test report page 3			
<b>Prüflaboratorium:</b> <i>Testing laboratory:</i>	TÜV Rheinland (China) Ltd.			
<b>Prüfergebnis*:</b> <i>Test result*:</i>	Pass			
<b>geprüft von:</b> <i>tested by:</i>	<u>Yanru tian/PE</u>			
<b>Datum:</b> <i>Date:</i>	2023-03-23	<b>Ausstellungsdatum:</b> <i>Issue date:</i>	2023-03-23	
<b>Stellung / Position:</b>	Sachverständige(r)/Expert	<b>Stellung / Position:</b>	Sachverständige(r)/Expert	
<b>Sonstiges /</b> <i>Other:</i>				
<b>Zustand des Prüfgegenstandes bei Anlieferung:</b> <i>Condition of the test item at delivery:</i>	Prüfmuster vollständig und unbeschädigt <i>Test item complete and undamaged</i>			
* Legende:	P(ass) = entspricht o.g. Prüfgrundlage(n)	F(ail) = entspricht nicht o.g. Prüfgrundlage(n)	N/A = nicht anwendbar	N/T = nicht getestet
* Legend:	P(ass) = passed a.m. test specification(s)	F(ail) = failed a.m. test specification(s)	N/A = not applicable	N/T = not tested
<p><b>Dieser Prüfbericht bezieht sich nur auf das o.g. Prüfmuster und darf ohne Genehmigung der Prüfstelle nicht auszugsweise vervielfältigt werden. Dieser Bericht berechtigt nicht zur Verwendung eines Prüfzeichens.</b>  <i>This test report only relates to the above mentioned test sample. Without permission of the test center this test report is not permitted to be duplicated in extracts. This test report does not entitle to carry any test mark.</i></p>				

v05

**Prüfbericht-Nr.:**  
Test report no.: CN23W62W 001

Seite 2 von 36  
Page 2 of 36

**Anmerkungen**  
*Remarks*

1	<p>Alle eingesetzten Prüfmittel waren zum angegebenen Prüfzeitraum gemäß eines festgelegten Kalibrierungsprogramms unseres Prüfhauses kalibriert. Sie entsprechen den in den Prüfprogrammen hinterlegten Anforderungen. Die Rückverfolgbarkeit der eingesetzten Prüfmittel ist durch die Einhaltung der Regelungen unseres Managementsystems gegeben. Detaillierte Informationen bezüglich Prüfkonditionen, Prüfequipment und Messunsicherheiten sind im Prüflabor vorhanden und können auf Wunsch bereitgestellt werden.</p> <p><i>The equipment used during the specified testing period was calibrated according to our test laboratory calibration program. The equipment fulfils the requirements included in the relevant standards. The traceability of the test equipment used is ensured by compliance with the regulations of our management system. Detailed information regarding test conditions, equipment and measurement uncertainty is available in the test laboratory and could be provided on request.</i></p>
2	<p>Wie vertraglich vereinbart, wurde dieses Dokument nur digital unterzeichnet. Der TÜV Rheinland hat nicht überprüft, welche rechtlichen oder sonstigen diesbezüglichen Anforderungen für dieses Dokument gelten. Diese Überprüfung liegt in der Verantwortung des Benutzers dieses Dokuments. Auf Verlangen des Kunden kann der TÜV Rheinland die Gültigkeit der digitalen Signatur durch ein gesondertes Dokument bestätigen. Diese Anfrage ist an unseren Vertrieb zu richten. Eine Umweltgebühr für einen solchen zusätzlichen Service wird erhoben.</p> <p><i>As contractually agreed, this document has been signed digitally only. TÜV Rheinland has not verified and unable to verify which legal or other pertaining requirements are applicable for this document. Such verification is within the responsibility of the user of this document. Upon request by its client, TÜV Rheinland can confirm the validity of the digital signature by a separate document. Such request shall be addressed to our Sales department. An environmental fee for such additional service will be charged.</i></p>
3	<p>Prüfklausel mit der Note * wurden an qualifizierte Unterauftragnehmer vergeben und sind unter der jeweiligen Prüfklausel des Berichts beschrieben. Abweichungen von Prüfspezifikation(en) oder Kundenanforderungen sind in der jeweiligen Prüfklausel im Bericht aufgeführt.</p> <p><i>Test clauses with remark of * are subcontracted to qualified subcontractors and described under the respective test clause in the report.</i> <i>Deviations of testing specification(s) or customer requirements are listed in specific test clause in the report.</i></p>
4	<p>Die Entscheidungsregel für Konformitätserklärungen basierend auf numerischen Messergebnissen in diesem Prüfbericht basiert auf der "Null-Grenzwert-Regel" und der "Einfachen Akzeptanz" gemäß ILAC G8:2019 und IEC Guide 115:2021, es sei denn, in der auf Seite 1 dieses Berichts genannten angewandten Norm ist etwas anderes festgelegt oder vom Kunden gewünscht. Dies bedeutet, dass die Messunsicherheit nicht berücksichtigt wird und daher auch nicht im Prüfbericht angegeben wird. Zu weiteren Informationen bezüglich des Risikos durch diese Entscheidungsregel siehe ILAC G8:2019.</p> <p><i>The decision rule for statements of conformity, based on numerical measurement results, in this test report is based on the "Zero Guard Band Rule" and "Simple Acceptance" in accordance with ILAC G8:2019 and IEC Guide 115:2021, unless otherwise specified in the applied standard mentioned on Page 1 of this report or requested by the customer. This means that measurement uncertainty is not taken in account and hence also not declared in the test report. For additional information to the resulting risk based of this decision rule please refer to ILAC G8:2019.</i></p>



<b>TEST REPORT</b> <b>EN IEC 62561-2</b> <b>Lightning protection system components (LPSC) –</b> <b>Part 2: Requirements for conductors and earth electrodes</b>	
<b>Report Number</b> .....:	CN23W62W 001
<b>Date of issue</b> .....:	See cover page
<b>Total number of pages</b> .....:	See cover page
<b>Name of Testing Laboratory preparing the Report</b> .....:	Sichuan Accuracy Test and Accreditation Co., Ltd.
<b>Applicant's name</b> .....	Beijing Keyichao Technology and Culture Development Co., Ltd
<b>Address</b> .....:	207, Floor 2, Building 5, Yard 17, Jinsha West Street, Mentougou District, 102300 Beijing P.R. China
<b>Test specification:</b>	
<b>Standard</b> .....	EN IEC 62561-2: 2018
<b>Test procedure</b> .....	TUV CoC procedure
<b>Non-standard test method</b> .....:	N/A
<b>TRF template used</b> .....	N/A
<b>Test Report Form No.</b> .....	N/A
<b>Test Report Form(s) Originator</b> ..:	TUV
<b>Master TRF</b> .....	N/A
<b>General disclaimer:</b>	
<p>The test results presented in this report relate only to the object tested.                  This report shall not be reproduced, except in full, without the written approval of the Issuing NCB. The authenticity of this Test Report and its contents can be verified by contacting the NCB, responsible for this Test Report.</p>	

<b>Test item description</b> .....:	air-termination rods	
<b>Trade Mark(s)</b> .....:	 or LeiAnTong	
<b>Manufacturer</b> .....:	Beijing Keyichao Technology and Culture Development Co., Ltd	
<b>Model/Type reference</b> .....:	KYC-LAT	
<b>Ratings</b> .....:	Conductor covering thickness: $\geq 2.5\mu\text{m}$	
<b>Responsible Testing Laboratory (as applicable), testing procedure and testing location(s):</b>		
<input type="checkbox"/>	<b>CB Testing Laboratory:</b>	
<b>Testing location/ address</b> .....:		
<b>Tested by (name, function, signature)</b> ....:		
<b>Approved by (name, function, signature)</b> .....:		
<input type="checkbox"/>	<b>Testing procedure: CTF Stage 1:</b>	
<b>Testing location/ address</b> .....:		
<b>Tested by (name, function, signature)</b> ....:		
<b>Approved by (name, function, signature)</b> .....:		
<input type="checkbox"/>	<b>Testing procedure: CTF Stage 2:</b>	
<b>Testing location/ address</b> .....:		
<b>Tested by (name + signature)</b> .....:		
<b>Witnessed by (name, function, signature)</b> .....:		
<b>Approved by (name, function, signature)</b> .....:		
<input type="checkbox"/>	<b>Testing procedure: CTF Stage 3:</b>	
<input type="checkbox"/>	<b>Testing procedure: CTF Stage 4:</b>	
<b>Testing location/ address</b> .....:		
<b>Tested by (name, function, signature)</b> ....:		
<b>Witnessed by (name, function, signature)</b> .....:		

<b>Approved by (name, function, signature)</b> .....:		
<b>Supervised by (name, function, signature)</b> .....:		

**List of Attachments (including a total number of pages in each attachment):**

Attachment 1: Test Equipment list (1 pages)  
Attachment 2: Photo Documentation (2 pages)

**Summary of testing:**
**Tests performed (name of test and test clause):**
**Test sequence 1:**

Marking test 4.5/5.5

**Test sequence 2:**

Air-termination conductors, air-termination rods, earth lead-in rods and down conductors 4.3

**Test sequence 3:**

Resistivity test 5.2.5

**Test sequence 4:**

Test for thickness of coating 5.2.2

**Test sequence 5:**

Tensile test 5.2.6

**Testing location:**

Sichuan Accuracy Test and Accreditation Co., Ltd.

No.19, Tianyu Rd, Western Park, Hi-Tech Zone, Chengdu, Sichuan, China

Chengdu Hanzhun Quality Testing CO.,LTD

2F, Building3, No.99, Wuhou District, Chengdu, China

**Summary of compliance with National Differences (List of countries addressed):**

N/A

The product fulfils the requirements of \_\_\_\_\_ (insert standard number and edition and delete the text in parenthesis, leave it blank or delete the whole sentence, if not applicable)

**Use of uncertainty of measurement for decisions on conformity (decision rule) :**

No decision rule is specified by the IEC standard, when comparing the measurement result with the applicable limit according to the specification in that standard. The decisions on conformity are made without applying the measurement uncertainty ("simple acceptance" decision rule, previously known as "accuracy method").

Other:... (to be specified, for example when required by the standard or client, or if national accreditation requirements apply)

**Information on uncertainty of measurement:**

The uncertainties of measurement are calculated by the laboratory based on application of criteria given by OD-5014 for test equipment and application of test methods, decision sheets and operational procedures of IECEE.

IEC Guide 115 provides guidance on the application of measurement uncertainty principles and applying the decision rule when reporting test results within IECEE scheme, noting that the reporting of the measurement uncertainty for measurements is not necessary unless required by the test standard or customer.

Calculations leading to the reported values are on file with the NCB and testing laboratory that conducted the testing.

**Copy of marking plate**

The artwork below may be only a draft. The use of certification marks on a product must be authorized by the respective NCBs that own these marks.

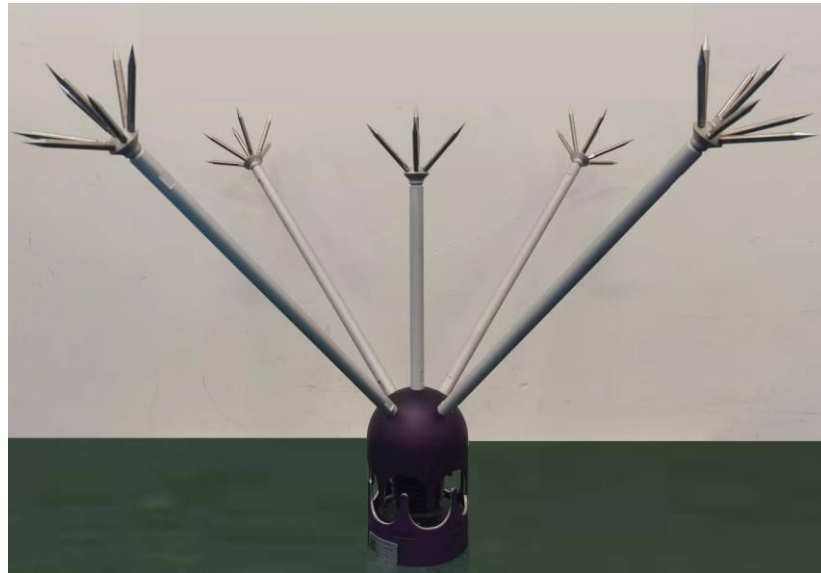

<b>Possible test case verdicts:</b>	
- test case does not apply to the test object ... : N/A	
- test object does meet the requirement ..... : P (Pass)	
- test object does not meet the requirement .. : F (Fail)	
<b>Testing</b> ..... :	
<b>Date of receipt of test item</b> ..... : 2023-03-09	
<b>Date (s) of performance of tests</b> ..... : 2023-03-14 to 2023-03-17	
<b>General remarks:</b>	
<p>"(See Enclosure #)" refers to additional information appended to the report.          "(See appended table)" refers to a table appended to the report.</p> <p>Throughout this report a <input checked="" type="checkbox"/> comma / <input type="checkbox"/> point is used as the decimal separator.</p> <p><input type="checkbox"/> This Test Report Form contains requirements according to IEC/ISO ..... Standard dated ..... and includes Corrigendum dated .....</p> <p>(Note: The above text maybe removed if not applicable)</p>	
<b>Manufacturer's Declaration per Sub-clause 4.2.5 of IEC/ISO 02::</b>	
<p>The application for obtaining a CB Test Certificate includes more than one factory location and a declaration from the Manufacturer stating that the sample(s) submitted for evaluation is (are) representative of the products from each factory has been provided.....:</p>	<p><input type="checkbox"/> Yes  <input checked="" type="checkbox"/> Not applicable</p>
<b>When differences exist; they shall be identified in the General product information section.</b>	

**Name and address of factory (ies) :** Beijing Keyichao Technology and Culture Development Co., Ltd  
207, Floor 2, Building 5, Yard 17, Jinsha West Street,  
Mentougou District, 102300 Beijing P.R. China

**General product information and other remarks:**

Conductor covering thickness:  $\geq 2.5\mu\text{m}$



EN IEC 62561-2			
Clause	Requirement + Test	Result - Remark	Verdict
<b>4</b>	<b>Requirements</b>		
<b>4.1</b>	<b>General</b>		
	Conductors and earth electrodes shall be designed in such a manner that, when they are installed in accordance with the manufacturer's instructions, their performance shall be reliable, stable and safe to persons and surrounding equipment.		N/A
	The choice of a material depends on its ability to match the particular application requirements such as life cycle of the material, effects from galvanic corrosion and compatibility with other interconnected materials or services.		N/A
	Summaries of the requirements are given in Annex C and Annex D and their corresponding tests are given in Annex A, Annex B and the sequence of tests in Annex E (Figure E.1), Annex F (Figure F.1) and Annex G (Figure G.1).		N/A
<b>4.2</b>	<b>Documentation</b>		
	The manufacturer or supplier of the conductors and earth electrodes shall provide adequate information in their literature to ensure that the installer of the conductors and earth electrodes can select and install the materials in a suitable and safe manner, in accordance with IEC 62305-3 and IEC 62305-4.		N/A
<b>4.3</b>	<b>Air-termination conductors, air-termination rods, earth lead-in rods and down conductors</b>		
	<p>The material, configuration and cross-sectional area of the conductors and rods, shall be in accordance with Table 1. Their mechanical and electrical characteristics shall be in accordance with Table 2.</p> <p>Material: Aluminium alloy Configurations: Hollow round rod Minimum cross-sectional area: <math>\geq 176 \text{ mm}^2</math></p>	<p>Guide rod (long): S: <math>271 \text{ mm}^2</math> Outer diameter: <math>20.20 \text{ mm}</math> Inner diameter: <math>7.90 \text{ mm}</math></p> <p>Guide rod (short): S: <math>272 \text{ mm}^2</math> Outer diameter: <math>20.10 \text{ mm}</math> Inner diameter: <math>7.90 \text{ mm}</math></p>	P

EN IEC 62561-2			
Clause	Requirement + Test	Result - Remark	Verdict
	Other materials may be used if they possess equivalent mechanical and electrical characteristics and corrosion resistance properties for the intended application.	—	N/A
	Other configurations may be used if the relevant dimensions are met.	Hollow round rod	P
	Coated conductors and rods shall be corrosion resistant and the coating shall exhibit good adherence to the base material.		P
	Compliance is checked by the tests of 5.2.2, 5.2.3, 5.2.4, 5.2.5 and 5.2.6.		N/A
<b>4.4</b>	<b>Earth electrodes</b>		
<b>4.4.1</b>	<b>General</b>		
	The cross-sectional area of earth electrodes, its material and its configuration shall be in accordance with Table 3. Moreover, its mechanical and electrical characteristics shall be in accordance with Table 2.		N/A
	Other materials may be used if they possess equivalent mechanical and electrical characteristics and corrosion resistance properties for the intended application.		N/A
	Other configurations may be used if the relevant dimensions are met.		N/A
<b>4.4.2</b>	<b>Earth rods</b>		
	Earth rods shall be mechanically robust to ensure correct installation. The material of choice shall be sufficiently malleable to ensure that no cracking of the rod takes place during installation.		N/A
	The threads on the rods, if any, shall be smooth and fully formed. For coated rods, the coating shall extend over the threads. A lead-in chamfer or point is recommended to facilitate driving.		N/A
<b>4.4.3</b>	<b>Couplers for earth rods</b>		N/A
	Earth rods can be extended allowing them to be driven deeper into the ground. This can be achieved by means of a joint/coupling device.	—	N/A

EN IEC 62561-2			
Clause	Requirement + Test	Result - Remark	Verdict
	The choice of material shall be compatible with that of the earth rod being joined.		N/A
	It shall be sufficiently mechanically robust to withstand the driving forces generated during installation.		
	It shall also exhibit good corrosion resistance.		N/A
	Threaded external couplers shall be of a sufficient length to ensure no threads on the earth rod are exposed when installed.		N/A
	Threaded internal couplers shall ensure that the mating faces of the earth rods come in contact after assembly.		N/A
	Compliance is checked by the tests of 5.4.2, 5.4.3, 5.4.4 and 5.4.5.		N/A
<b>4.4.4</b>	<b>Earth conductors and earth plates</b>		
	Earth electrode conductors and earth plates shall be corrosion resistant and any coating shall exhibit good adherence to the base material.		N/A
	Compliance is checked by the test of 5.2.2, 5.2.3, 5.2.4, 5.2.5 and 5.2.6		N/A
<b>4.5</b>	<b>Marking</b>		
	All products complying with this document shall be marked at least with the manufacturer's or responsible vendor's name or trade mark or identifying symbol.		P
	Where this proves to be impractical, the marking in accordance with the identifying symbol may be given on the smallest packing unit.		N/A
	Compliance is checked in accordance with 5.5		P
<b>5</b>	<b>Tests</b>		

EN IEC 62561-2			
Clause	Requirement + Test	Result - Remark	Verdict
<b>5.1</b>	<b>General conditions for tests</b>		N/A
	Tests according to this document are type tests. These tests are of such a nature that, after they have been performed, they need not be repeated unless changes are made to the materials, design or type of manufacturing process, which might change the performance characteristics of the product.		N/A
	– Unless otherwise specified, all tests are carried out on new specimens.		N/A
	– Unless otherwise specified, three specimens are subjected to the tests and the requirements are satisfied if all the tests are met.		N/A
	– If only one of the specimens does not satisfy a test, due to an assembly or a manufacturing fault, that test and any preceding one which may have influenced the results of the test shall be repeated and also the tests that follow shall be carried out in the required sequence on another full set of specimens, all of which shall comply with the requirements.		N/A
	The applicant, when submitting a set of specimens, may also submit an additional set of specimens, which may be necessary should one specimen fail. The testing laboratory will then, without further request, test the additional set of specimens and will reject it only if a further failure occurs. If the additional set of specimens is not submitted at the same time, the failure of one specimen will entail rejection.		N/A
<b>5.2</b>	<b>Air termination conductors, air-termination rods, earth lead-in rods, earth conductors and earth plate</b>		
<b>5.2.1</b>	<b>General</b>		
	Air-termination conductors, air-termination rods, earth lead-in rods, down-conductors and earth conductors and earth plates shall be subjected to the following tests to confirm their suitability for the intended application.		N/A
	Earth electrodes shall be subjected to the tests according to Annex D.		N/A

EN IEC 62561-2			
Clause	Requirement + Test	Result - Remark	Verdict
	Air-termination conductors, air-termination rods, earth lead-in rods, earth conductors and earth plate shall be subjected to the tests according to Annex E.		N/A
<b>5.2.2</b>	<b>Test for thickness of coating</b>		
<b>5.2.2.1</b>	<b>General conditions for tests</b>		
	Specimens each approximately 500 mm long shall be subjected to a test for copper or zinc coating thickness.		N/A
	The copper or the zinc coating on a steel core specimen shall be measured using a magnetic method instrument complying with ISO 2178. Zinc coating can also be measured in accordance with ISO 1460 or ISO 1461. When this test method is used, the length of specimens can be reduced.		N/A
	For round specimens, measurements should be taken at three positions along the length of the specimen: one 50 mm from the top, one 50 mm from the bottom and one at the midpoint.	50mm from the top: Point1: 14.2 µm Point2: 14.7 µm Point3: 15.2 µm Point4: 15.0 µm Point5: 15.3 µm 50mm from the bottom : Point1: 15.3 µm Point2: 15.1 µm Point3: 14.8 µm Point4: 14.5 µm Point5: 14.9 µm midpoint.: Point1: 15.1 µm Point2: 15.7 µm Point3: 15.2 µm Point4: 15.1 µm Point5: 15.2 µm Other points: Point1: 14.9 µm Point2: 15.2 µm Point3: 15.1 µm Point4: 14.9 µm Point5: 15.1 µm	P
	At each position detailed above, two additional measurements should be taken around the circumference of the specimen at approximately 120° separation (see keys 1, 2, 3 in Figure 1).		P

EN IEC 62561-2			
Clause	Requirement + Test	Result - Remark	Verdict
	For flat specimens, measurements should be taken from both sides at three positions along the length of the material. All three measurements shall be taken in the middle of the width of the material in the following locations: 50 mm from the top, 50 mm from the bottom and at the mid-point (see keys 1, 2 in Figure 2).		N/A
	There is no requirement to measure the thickness of the tin plating on copper because it is applied for aesthetic reasons only.		N/A
<b>5.2.2.2</b>	<b>Acceptance criteria</b>		P
	The specimens are deemed to have passed the tests if they comply with the requirements of Table 1 for air-termination conductors, air-termination rods, earth lead-in rods, down conductors and Table 3 for earth conductors and earth plates . Additionally, the zinc galvanizing coating shall be smooth, continuous and free from flux stains with a minimum weight of 350 g/m <sup>2</sup> for solid round specimens and 500 g/m <sup>2</sup> for solid tape specimens. Manufacture's thickness of coating: ≥2.5µm	Minimum measured thickness of coating: 14.2µm	P
<b>5.2.3</b>	<b>Bend and adhesion test for coated conductors</b>		N/A
<b>5.2.3.1</b>	<b>General conditions for tests</b>		N/A
	Coated conductors each approximately 500 mm long shall be bent to an angle of (90 <sub>0</sub> <sup>+5</sup> )°:  <ul style="list-style-type: none"> <li>• for a round conductor, the bending radius shall be equal to 5 times (± 1 mm) its diameter;</li> <li>• for a tape conductor, the bending radius shall be equal to 5 times (± 1 mm) its thickness.</li> </ul>		N/A
<b>5.2.3.2</b>	<b>Acceptance criteria</b>		N/A
	After the test, the specimens shall show no sharp edges, cracks or peeling when inspected with normal or corrected vision without magnification.		N/A
<b>5.2.4</b>	<b>Environmental test for coated materials</b>		N/A
<b>5.2.5</b>	<b>Resistivity test</b>		
<b>5.2.5.1</b>	<b>General conditions for tests</b>		

EN IEC 62561-2			
Clause	Requirement + Test	Result - Remark	Verdict
	A sample length, approximately 1.2 m long, should be used for the test. The resistance measurement should be taken over a 1 m ( $\pm 1$ mm) distance, using a micro ohmmeter, and the reading corrected to a temperature of 20 °C using appropriate correction factors	T: 19.0°C L: YP01:0.50m YP02:0.50m YP03:0.50m R(19.0°C): YP01: 5.5μΩ YP02: 4.8μΩ YP03: 5.1μΩ R(20°C):(k:1.004) YP01: 5.52μΩ YP02: 4.82μΩ YP03: 5.12μΩ	P
	The resistivity of the sample length can then be found by the formula:		P
	$\rho = \frac{R \times a}{\ell} \text{ (}\Omega\text{m)}$ <p>where: R is the resistance in Ω over a 1 m length; a is the cross-sectional area (m<sup>2</sup>); ℓ is the unit length (m). The dimensions of the sample shall be measured at three equally distributed points along a 1 m length and its cross-sectional area should be within a <math>\pm 5</math> % tolerance.</p>	Measured value a: YP01: 0.000272 m <sup>2</sup> YP02: 0.000271 m <sup>2</sup> YP03: 0.000285 m <sup>2</sup>  Calculation results ρ : YP01: 0.0300μΩ • m YP02: 0.0261μΩ • m YP03: 0.0292μΩ • m	P
<b>5.2.5.2</b>	<b>Acceptance criteria</b>		
	The specimens are deemed to have passed the tests if they comply with the requirements of Table 2.	$\leq 0.036 \mu\Omega \cdot m$	P
<b>5.2.6</b>	<b>Tensile test</b>		
<b>5.2.6.1</b>	<b>General conditions for tests</b>		
	For the methodology of carrying out tensile strength (Rm), see ISO 6892-1. For the testing of air-termination conductors, air-termination rods, earth lead-in rods, down conductors, earth conductors and earth plates, the test specimen shall be tested according to ISO 6892-1.	Tensile rate: 5mm/min	P

EN IEC 62561-2			
Clause	Requirement + Test	Result - Remark	Verdict
<b>5.2.6.2</b>	<b>Acceptance criteria</b>		
	The specimens are deemed to have passed the tests if they comply with the requirements of Table 2.  Aluminium alloy: 120~280 N/mm <sup>2</sup>	R <sub>m</sub> : YP01: 253 N/mm <sup>2</sup> YP02: 255 N/mm <sup>2</sup> YP03: 259 N/mm <sup>2</sup>	P
<b>5.3</b>	<b>Earth rods</b>		
<b>5.3.1</b>	<b>General</b>		
	Earth rods shall be subjected to the tests according to Annex F.		N/A
<b>5.3.2</b>	<b>Test for thickness of coating on earth rods</b>		N/A
<b>5.3.2.1</b>	<b>General conditions for tests</b>		
	Test conditions are described in 5.2.2.1.		N/A
<b>5.3.2.2</b>	<b>Acceptance criteria</b>		
	The specimens are deemed to have passed the tests if they comply with the requirements of Table 3.		N/A
	Additionally, for the zinc coated earth rods, the coating shall be smooth, continuous and free from flux stains with a minimum weight of 350 g/m <sup>2</sup> .		N/A
<b>5.3.3</b>	<b>Adhesion test.</b>		
	During this test, the conductor shall not move noticeably in the terminal		N/A
<b>5.3.3.1</b>	<b>General conditions for tests</b>		N/A
	The copper-coated steel earth rod specimens, used in, and complying with, 5.3.2, with one end cut to an angle of approximately 45° shall be subjected to the following test.		N/A
	The specimens are driven through two steel clamping plates or the jaws of a vice set (1 <sub>-0,250<sup>00</sup></sub> ) mm less than the diameter of the specimens, so as to shear off sufficient metal to expose the bond between the coating and the parent metal. A test arrangement for the adhesion test is shown in Figure 3.		N/A



EN IEC 62561-2			
Clause	Requirement + Test	Result - Remark	Verdict
<b>5.3.3.2</b>	<b>Acceptance criteria</b>		
	After the test, the coating of the specimens shall show adherence to the parent metal. Separation of the copper from the steel is not acceptable.		N/A
<b>5.3.4</b>	<b>Bend test</b>		
<b>5.3.4.1</b>	<b>General conditions for tests</b>		
	The copper coated steel earth rod specimens used in and complying with 5.3.3 shall be bent through a radius equal to 5 times ( $\pm 1$ mm) of their diameter to an angle of $(90 \pm 5)^\circ$ .		N/A
<b>5.3.4.2</b>	<b>Acceptance criteria</b>		
	After the test, the specimens shall satisfy the following criteria: a) the specimens shall not show sharp edges, cracks or peeling around the bending area when inspected with normal or corrected vision without magnification; b) the base metal shall not exhibit any visual corrosive deterioration when inspected with normal or corrected vision without magnification.		N/A  N/A
<b>5.3.5</b>	<b>Environmental test for coated earth rods</b>		
<b>5.3.5.1</b>	<b>General conditions for tests</b>		
	The copper coated steel earth rods specimens used in and complying with 5.3.4 and the zinc coated earth rods specimens used and complying with 5.3.2 shall be subjected to an environmental test as specified in Clause A.2 followed by a humid sulphurous atmosphere treatment as specified in Clause A.3		N/A
<b>5.3.5.2</b>	<b>Acceptance criteria</b>		

EN IEC 62561-2			
Clause	Requirement + Test	Result - Remark	Verdict
	<p>After the test, the specimens shall satisfy the following criteria.</p> <p>a) The specimens shall be of good visual appearance and have no rough edges or burrs throughout their length.</p> <p>b) The base metal of the specimens shall not exhibit any visual corrosive deterioration when inspected with normal or corrected vision without magnification. 100 mm from both ends of the specimens are excluded from inspection.</p> <p>c) The electrical resistance over a 100 mm length measured after the tests shall not exceed the resistance value measured before the tests by more than 50 %.</p> <p>White rust is not considered as corrosive deterioration.</p>		N/A  N/A  N/A
<b>5.3.6</b>	<b>Electrical resistivity test</b>		
<b>5.3.6.1</b>	<b>General conditions for tests</b>		
	<p>A sample length of earth rod, approximately 1,2 m long should be used for the test. The resistance measurement should be taken over a 1 m (<math>\pm 1</math> mm) distance, using a micro ohmmeter, and the reading corrected to a temperature of 20 °C, using appropriate correction factors.</p>		N/A
	<p>The resistivity of the sample length of the earth rod can then be calculated using the formula:</p> $\rho = \frac{R \times a}{\ell} \text{ (}\mu\Omega\text{m)}$ <p>where</p> <p><math>R</math> is the resistance in micro-ohms (<math>\mu\Omega</math>) over a 1 m length;</p> <p><math>a</math> is the cross-sectional area (<math>\text{m}^2</math>);</p> <p><math>\ell</math> is the unit length (m),</p> <p>The dimensions of the earth rod should be measured at three equally distributed points along a 1 m length and its cross-sectional area should be within a <math>\pm 5</math> % tolerance.</p>		N/A

EN IEC 62561-2			
Clause	Requirement + Test	Result - Remark	Verdict
<b>5.3.6.2</b>	<b>Acceptance criteria</b>		
	The specimens are deemed to have passed the tests if they comply with the requirements of Table 2.		
<b>5.3.7</b>	<b>Tensile strength test</b>		
<b>5.3.7.1</b>	<b>General conditions for tests</b>		
	For the methodology of carrying out tensile strength (Rm), see ISO 6892-1.		N/A
<b>5.3.7.2</b>	<b>Acceptance criteria</b>		
	The specimens are deemed to have passed the tests if they comply with the requirements of Table 2.		N/A
<b>5.3.8</b>	<b>Test for yield/tensile ratio</b>		
<b>5.3.8.1</b>	<b>General conditions for tests</b>		
	The yield/tensile ratio is determined by ascertaining the upper yield strength (ReH) and dividing the result by the tensile strength (Rm), (see Figure 4).		N/A
<b>5.3.8.2</b>	<b>Acceptance criteria</b>		
	The specimens are deemed to have passed the tests if they comply with the requirements of Table 2.		N/A
<b>5.4</b>	<b>Couplers for earth rods</b>		
<b>5.4.1</b>	<b>General</b>		
	Couplers for earth rods shall be subjected to the following tests to confirm their suitability for the intended application.		N/A
<b>5.4.2</b>	<b>Compression test by mechanical means</b>		
	Each specimen shall be assembled from two sections of earth rod, each 500 mm long. The tests shall be performed with suitable driving heads and driving tools following the manufacturer's or supplier's instructions.		N/A

EN IEC 62561-2			
Clause	Requirement + Test	Result - Remark	Verdict
	<p>The top of the specimens shall be impacted with a vibration hammer defined with the following parameters for a duration of 1 min:</p> <ul style="list-style-type: none"> <li>– percussion rate (2 000 ± 1 000) min<sup>-1</sup>;</li> <li>– Single stroke impact energy (50 ± 10) Nm.</li> </ul> <p>A typical test arrangement is shown in Figure 5.</p>		N/A N/A
<b>5.4.2.2</b>	<b>Acceptance criteria</b>		
	The specimens are deemed to have passed the tests if their couplers are not broken or do not show any crack to normal or corrected vision without magnification.		N/A
<b>5.4.3</b>	<b>Environmental test</b>		
<b>5.4.3.1</b>	<b>General conditions for tests</b>		
	Specimen assemblies used in and complying with 5.4.2 shall be subjected to an environmental test as specified in Annex A. The manufacturer or supplier shall provide proof of the copper content of any part of the assembly made from an alloy copper		N/A
<b>5.4.3.2</b>	<b>Acceptance criteria</b>		
	<p>The specimens are deemed to have passed the tests if:</p> <ul style="list-style-type: none"> <li>a) the specimen assembly remains intact;</li> <li>b) the base metal of the specimens shall not exhibit any visual corrosive deterioration when inspected with normal or corrected vision without magnification. 100 mm from both ends of the specimens are excluded from inspection.</li> </ul> <p>White rust is not considered as corrosive deterioration.</p>		N/A N/A
<b>5.4.4</b>	<b>Electrical test</b>		
	Specimen assemblies used in and complying with 5.4.3 shall be subjected, without cleaning, to an electrical test according to Clause B.1.		N/A
<b>5.4.5</b>	<b>Tensile strength test</b>		

EN IEC 62561-2			
Clause	Requirement + Test	Result - Remark	Verdict
<b>5.4.5.1</b>	<b>General conditions for tests</b>		
	Specimen assemblies, used in and complying with 5.4.4, shall be subjected to a mechanical tensile force of 1 000 N ( $\pm 10$ N).	_____ N	N/A
<b>5.4.5.2</b>	<b>Acceptance criteria</b>		
	After the tests as per 5.4.4 and 5.4.5, the specimens shall satisfy the criteria according to Clause B.2.		N/A
<b>5.5</b>	<b>Marking test</b>		
<b>5.5.1</b>	<b>General conditions for tests</b>		
	The marking is checked by inspection and by rubbing it by hand for 15 s with a piece of cloth soaked with water and again for 15 s with a piece of cloth soaked with white spirit/mineral spirit.		P
	Marking made by moulding, pressing or engraving is not subjected to this test.		N/A
<b>5.5.2</b>	<b>Acceptance criteria</b>		
	The specimen is deemed to have passed the test if the marking remains legible.	The marking remains legible after the test.	P
<b>6</b>	<b>Electromagnetic compatibility (EMC)</b>		
	Products covered by this document are, in normal use, passive in respect of electromagnetic influences (emission and immunity).		N/A

**Table 1 – Material, configuration and cross-sectional area of air-termination conductors, air-termination rods, earth lead-in rods<sup>g</sup> and down-conductors**

Material	Configuration	Cross-sectional area <sup>a</sup> mm <sup>2</sup>	Recommended dimensions
Copper, Tin plated copper <sup>b</sup>	Solid tape	≥ 50	2 mm thickness
	Solid round <sup>d</sup>	≥ 50	8 mm diameter
	Stranded <sup>f</sup>	≥ 50	1,14 mm up to 1,7 mm strand diameter
	Rod solid round <sup>h</sup>	≥ 176	15 mm diameter
Aluminium	Solid tape	≥ 70	3 mm thickness
	Solid round	≥ 50	8 mm diameter
	Stranded <sup>f</sup>	≥ 50	1,63 mm strand diameter
Copper coated aluminium alloy <sup>e</sup>	Solid round	≥ 50	8 mm diameter
Aluminium alloy	Solid tape	≥ 50	2,5 mm thickness
	Solid round	≥ 50	8 mm diameter
	Stranded <sup>f</sup>	≥ 50	1,7 mm strand diameter
	Rod solid round <sup>h</sup>	≥ 176	15 mm diameter
Hot dipped galvanized steel	Solid tape	≥ 50	2,5 mm thickness
	Solid round	≥ 50	8 mm diameter
	Stranded <sup>f</sup>	≥ 50	1,7 mm strand diameter
	Rod solid round <sup>h</sup>	≥ 176	15 mm diameter
Copper coated steel <sup>e</sup>	Solid round	≥ 50	8 mm diameter
	Solid tape	≥ 50	2,5 mm thickness
Stainless steel <sup>c</sup>	Solid tape <sup>i</sup>	≥ 50	2 mm thickness
	Solid round <sup>i</sup>	≥ 50	8 mm diameter
	Stranded <sup>f</sup>	≥ 70	1,7 mm strand diameter
	Rod Solid round <sup>h</sup>	≥ 176	15 mm diameter

NOTE For the application of the conductors, see IEC 62305-3.

<sup>a</sup> Manufacturing tolerance: -3 %.

<sup>b</sup> Hot dipped or electroplated; minimum thickness coating of 1 µm. There is no requirement to measure the tin plated copper because it is for aesthetic reasons only.

<sup>c</sup> Chromium ≥ 16 %; nickel ≥ 8 %; carbon ≤ 0,08 %.

<sup>d</sup> 50 mm<sup>2</sup> (8 mm in diameter) may be reduced to 28 mm<sup>2</sup> (6 mm in diameter) in certain applications where mechanical strength is not an essential requirement. Consideration should, in this case, be given to reducing the spacing between the fasteners.

<sup>e</sup> Minimum 70 µm radial copper coating of 99,9 % copper content.

<sup>f</sup> The cross-sectional area of stranded conductors is determined by the resistance of the conductor according to IEC 60228.

<sup>g</sup> If the earth lead-in rod is partially installed in soil it has to fulfil the requirements of Table 2 and Table 3.

<sup>h</sup> Applicable for air-termination rods and earth lead-in rods. For air-termination rods where mechanical stress such as wind loading is not critical, a 9,5-mm diameter, 1-m long rod may be used.

<sup>i</sup> If thermal and mechanical considerations are important then these values should be increased to 75 mm<sup>2</sup>.

**Table 2 – Mechanical and electrical characteristics of air-termination conductors, air-termination rods, earth lead-in rods, down-conductors and earth electrodes**

Material	Maximum electrical resistivity $\mu\Omega\text{m}$	Tensile strength $\text{N/mm}^2$
Copper	0,018	200 to 450
Aluminium	0,03	$\leq 150$
Copper coated aluminium	0,03	$\leq 150^b$
Aluminium alloy	0,036	120 to 280
Steel	0,25	290 to 510
Steel (earth rods)	0,25	350 to 770
Copper coated steel	0,25	290 to 510 <sup>b</sup>
Copper coated steel (earth rods) <sup>a</sup>	0,25	350 to 770 <sup>b</sup>
Stainless steel	0,80	350 to 770
<sup>a</sup> Yield/tensile ratio 0,80 to 0,95		
<sup>b</sup> Based on dimensions/tests of only core material of coated conductors.		

**Table 3 – Material, configuration and cross-sectional area of earth electrodes**

Material	Configuration	Cross-sectional area <sup>a</sup>			Recommended dimensions
		Earth rod mm <sup>2</sup>	Earth conductor mm <sup>2</sup>	Earth plate cm <sup>2</sup>	
Copper, Tin plated copper <sup>f</sup>	Stranded		≥ 50 <sup>i</sup>		1,7 mm strand diameter
	Solid round		≥ 50		8 mm diameter
	Solid tape		≥ 50		2 mm thick
	Solid round	≥ 176			15 mm diameter
	Pipe	≥ 110			20 mm diameter with 2 mm wall thickness
	Solid plate			≥ 2 500	500 mm × 500 mm and 1,5 mm thick <sup>g</sup>
	Lattice plate <sup>g</sup>			≥ 3 600	600 mm × 600 mm consisted of 25 mm × 2 mm section for tape or 8 mm diameter for round conductor
Hot dipped galvanized steel	Solid round		≥ 78		10 mm diameter
	Solid round	≥ 150 <sup>b</sup>			14 mm diameter
	Pipe	≥ 140 <sup>b</sup>			25 mm diameter with 2 mm wall thickness
	Solid tape		≥ 90		3 mm thick
	Solid plate			≥ 2 500	500 mm × 500 mm and 3 mm thick
	Lattice plate <sup>d</sup>			≥ 3 600	600 mm × 600 mm consisted of 30 mm × 3 mm section for tape or 10 mm diameter for round conductor
	Profile	*			3 mm thick
Bare steel <sup>k</sup>	Stranded		≥ 70		1,7 mm strand diameter
	Solid round		≥ 78		10 mm diameter
	Solid tape		≥ 75		3 mm thick
Copper coated steel <sup>c</sup>	Solid round	≥ 150 <sup>h</sup>			14 mm diameter if 250 μm minimum radial copper coating with 99,9 % copper content
	Solid round		≥ 50		8 mm diameter, if 250 μm minimum radial copper coating of 99,9 % copper content
	Solid round <sup>i</sup>		≥ 78		10 mm diameter, if 250 μm minimum radial copper coating of 99,9 % copper content
	Solid tape <sup>i</sup>		≥ 90		3 mm thick, if 250 μm minimum copper coating of 99,9 % copper content
Stainless steel <sup>l</sup>	Solid round		≥ 78		10 mm diameter
	Solid round	≥ 176 <sup>h</sup>			15 mm diameter
	Solid tape		≥ 100		2 mm thick

NOTE For the application of the earth electrodes, see IEC 62305-3.

<sup>a</sup> Manufacturing tolerance: -3 %.
<sup>b</sup> Threads, where utilized, shall be machined prior to galvanizing.
<sup>c</sup> The copper shall be intrinsically bonded to the steel. The coating can be measured using an electronic coating measuring thickness instrument.
<sup>d</sup> Lattice plate constructed with a minimum total conductor length of 4,8 m.
<sup>e</sup> Different profiles are permitted with a cross section of 290 mm <sup>2</sup> and a minimum thickness of 3 mm, e.g. cross profile.
<sup>f</sup> Hot dipped or electroplated; minimum thickness coating of 1 μm. There is no requirement to measure the tin plated copper because it is for aesthetic reasons only.
<sup>g</sup> In some countries, the cross-sectional area may be reduced to ≥ 1 800 cm <sup>2</sup> and the thickness to ≥ 0,8 mm.
<sup>h</sup> In some countries, the cross-sectional area may be reduced to 125 mm <sup>2</sup> .
<sup>i</sup> The cross-sectional area of stranded conductors is determined by the resistance of the conductor according to IEC 60228.
<sup>j</sup> Chromium ≥ 16 %, nickel ≥ 5 %, molybdenum ≥ 2 %, carbon ≤ 0,08 %.
<sup>k</sup> Shall be embedded in concrete for a minimum depth of 50 mm.
<sup>l</sup> Due to higher corrosion rate for solid tape earth conductors, it is recommended to use copper-coated steel with a coating of 250 μm.



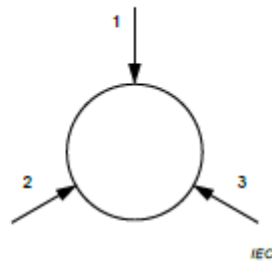

**Key**

1, 2, 3 position of measurements

**Figure 1 – Coating measurements around the circumference of a round conductor**

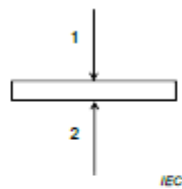

**Key**

1, 2 position of measurements

**Figure 2 – Coating measurements of a plate conductor**

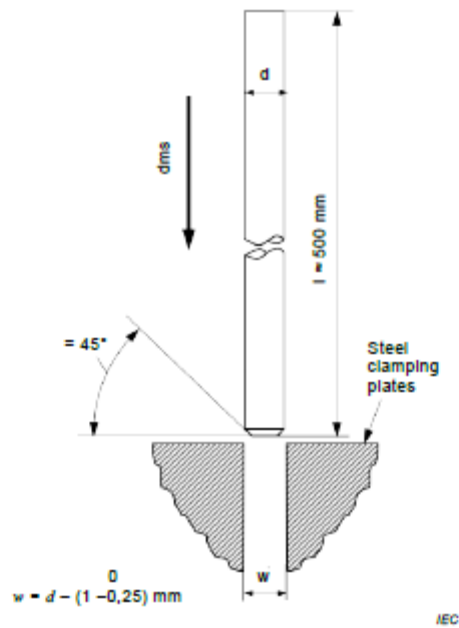

**Key**

dms direction of mechanical stress

**Figure 3 – Typical test arrangement for adhesion test**

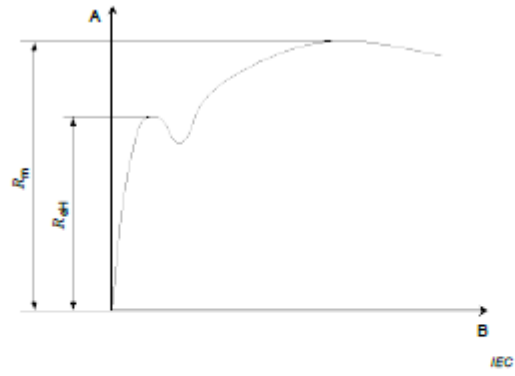
**Key**

A tensile strength

B elongation

**Figure 4 – Definitions of upper yield strength  $R_{eH}$  and tensile strength  $R_m$**

A typical test arrangement is shown in Figure 5.

*Dimensions in mm*

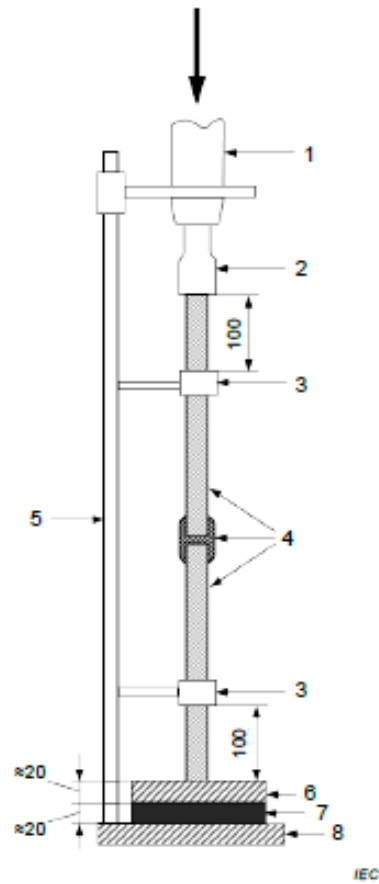

**Key**

- 1 vibration hammer
- 2 driving head
- 3 bearing
- 4 specimen
- 5 test holder
- 6 metal plate approx. 200 mm × 200 mm × 20 mm
- 7 rubber mat approx. 200 mm × 200 mm × 20 mm, hardness 80 – 85 shore
- 8 metal base

**Figure 5 – Typical test arrangement for the compression test by mechanical means**

## **Annex A** (normative)

### **Environmental test for conductors, air-termination rods and earth lead-in rods**

#### **A.1 General**

The conditioning/ageing test consists of a salt mist treatment as specified in Clause A.2 followed by a humid sulphurous atmosphere treatment as specified in Clause A.3 and an additional ammonia atmosphere treatment as specified in Clause A.4 for specimens where any component part is made of copper alloy with a copper content less than 80 %.

The manufacturer or supplier shall provide proof of the copper content of any part of the assembly made from an alloy of copper.

#### **A.2 Salt mist treatment**

The salt mist treatment shall be in accordance with IEC 60068-2-52:1996, except for Clauses 7, 10 and 11 which are not applicable. The test is carried out using severity (2).

If the salt mist chamber can maintain the temperature conditions as specified in 9.3 of IEC 60068-2-52:1996, and a relative humidity of not less than 90 %, then the specimen may remain in chamber for the humidity storage period.

#### **A.3 Humid sulphurous atmosphere treatment**

The humid sulphurous atmosphere treatment shall be in accordance with ISO 6988:1985 with seven cycles with a concentration in volume of sulphur dioxide of  $667 \times 10^{-6} \pm 25 \times 10^{-6}$ , except for Clauses 9 and 10 which are not applicable.

Each cycle which has duration of 24 h is composed of a heating period of 8 h at a temperature of  $40 \text{ °C} \pm 3 \text{ °C}$  in the humid saturated atmosphere which is followed by a rest period of 16 h. After that, the humid sulphurous atmosphere is replaced.

If the test chamber maintains the temperature conditions as specified in 6.5.2 of ISO 6988:1985, then the specimen may remain in the chamber for the storage period.

#### **A.4 Ammonia atmosphere treatment**

The ammonia atmosphere treatment shall be in accordance with ISO 6957:1988 for a moderate atmosphere with the pH value 10, except for Clauses 8.4 and 9, which are not applicable.

## Annex B (normative)

### Electrical test

#### B.1 General

Each specimen shall be stressed three times by a test current as given in Table B.1. The time interval between individual shots shall allow the arrangement of the specimen to cool down to approximately ambient temperature.

The impulse discharge current passing through the device under test is defined by the peak value  $I_{imp}$ , and the specific energy  $W/R$ . The impulse current shall show no reversal and reach  $I_{imp}$  within 50  $\mu$ s. The transfer of the specific energy  $W/R$  shall be dissipated within 5 ms.

**Table B.1 – Lightning impulse current ( $I_{imp}$ ) parameters**

$I_{imp}$ kA -10/+10%	$W/R$ kJ/ $\Omega$ -10/+45 %
100	2 500
NOTE The parameters specified above can typically be achieved by an exponential decaying current in the range of 350 $\mu$ s according to IEC 62305-1.	

#### B.2 Acceptance criteria

The specimens are deemed to have passed the tests if:

- a) the couplers are not broken or do not show any crack to normal or corrected vision without magnification;
- b) the contact resistance measured with a source of at least 10 A, as close as possible to the coupler, is equal to or less than 1 m $\Omega$ . In the case where the earth rod joint or the earth rods are of stainless steel, a value of equal to or less than 3 m $\Omega$  is allowed;
- c) the specimen assembly still remains intact.

## Annex C (normative)

### AC1 Requirements and tests for conductors AC1

Table C.1 is a summary of requirements for cross-sectional area, mechanical and electrical characteristics as well as tests to be applied for air-termination conductors, air-termination rods, earth lead-in rods and down-conductors according to Table 1 and Table 2.

**Table C.1 – Summary of requirements for various elements tested according to Table 1 and Table 2**

Material	Configuration	Cross-sectional area, mechanical and electrical characteristics, tests to be applied
Copper Tin plated copper	Solid tape Solid round Stranded	Table 1 / Table 2 Tests: Footnotes of Table 1, 5.2.5 / 5.2.6 / 5.5
Aluminium	Solid tape Solid round Stranded	Table 1 / Table 2 Tests: Footnotes of Table 1, 5.2.5 / 5.2.6 / 5.5
Copper coated aluminium alloy	Solid round	Table 1 / Table 2 Tests: Footnotes of Table 1 and Table 2, 5.2.2 / 5.2.3 / 5.2.4 / 5.2.5 / 5.2.6 / 5.5
Aluminium alloy	Solid tape Solid round Stranded	Table 1 / Table 2 Tests: Footnotes of Table 1, 5.2.5 / 5.2.6 / 5.5
Hot dipped galvanized steel	Solid tape Solid round Stranded	Table 1 / Table 2 Tests: Footnotes of Table 1, 5.2.2 / 5.2.3 / 5.2.4 / 5.2.5 / 5.2.6 / 5.5
Copper coated steel	Solid round Solid tape	Table 1 / Table 2 Tests: Footnotes of Table 1 and Table 2, 5.2.2 / 5.2.3 / 5.2.4 / 5.2.5 / 5.2.6 / 5.5
Stainless steel	Solid tape Solid round Stranded	Table 1 / Table 2 Tests: Footnotes of Table 1, 5.2.5 / 5.2.6 / 5.5

## Annex D (normative)

### (AC1) Requirements and tests for earth electrodes (AC1)

Table D.1 is a summary of requirements for dimensions, mechanical and electrical characteristics as well as tests to be applied for earth electrodes according to Table 2 and Table 3.

**Table D.1 – Summary of requirements for various elements tested according to Table 2 and Table 3**

Material	Configuration	Application	Dimensions, mechanical electrical characteristics, tests to be applied
Copper	Solid round	Earth conductor	Table 2 / Table 3 Tests: Footnotes of Table 3, 5.2.5 / 5.2.6 / 5.3.6 / 5.3.7 / 5.5
	Solid round	Earth rod	
	Solid tape	Earth conductor	
	Pipe	Earth rod	
	Solid plate	Earth plate	
	Lattice plate	Earth plate	
	Stranded	Earth conductor	
Galvanized steel	Solid round	Earth conductor	Table 2 / Table 3 Tests: Footnotes of Table 3, 5.2.2 / 5.2.3 / 5.2.4 / 5.2.5 / 5.2.6 / 5.5
	Solid tape	Earth conductor	
	Solid plate	Earth plate	
	Lattice plate	Earth plate	
	Stranded	Earth conductor	
Galvanized steel	Solid round	Earth rod	Table 2 / Table 3 Tests: Footnotes of Table 3, 5.3.2 / 5.3.5 / 5.3.6 / 5.3.7 / 5.5
	Pipe	Earth rod	
	Profile	Earth rod	
Bare steel	Solid round	Earth conductor	Table 2 / Table 3 Tests: Footnotes of Table 3, 5.2.5 / 5.2.6 / 5.5
	Solid tape	Earth conductor	
Copper coated steel	Solid round	Earth rod	Table 2 / Table 3 Tests: Footnotes of Table 2 and Table 3, 5.3.2 / 5.3.3 / 5.3.4 / 5.3.5 / 5.3.6 / 5.3.7 / 5.3.8 / 5.5
Copper coated steel	Solid round	Earth conductor	Table 2 / Table 3 Tests: Footnotes of Table 2 and Table 3, 5.2.2 / 5.2.3 / 5.2.4 / 5.2.5 / 5.2.6 / 5.5
	Solid tape	Earth conductor	
Stainless steel	Solid round	Earth conductor	Table 2 / Table 3 Tests: Footnotes of Table 3, 5.2.5 / 5.2.6 / 5.3.6 / 5.3.7 / 5.5
	Solid round	Earth rod	
	Solid tape	Earth conductor	
Couplers for earth rods	—	—	Tests: Footnotes of Table 3, 5.4.2 / 5.4.3 / 5.4.4 / 5.4.5 / 5.5. In addition tests according to IEC 62561-1:2017, 6.3

(AC1)

**Annex E**  
(normative)

**Flow chart of tests for air-termination conductors, air-termination rods, earth lead-in rods, down-conductors, earth conductors and earth plates, see Figure E.1**

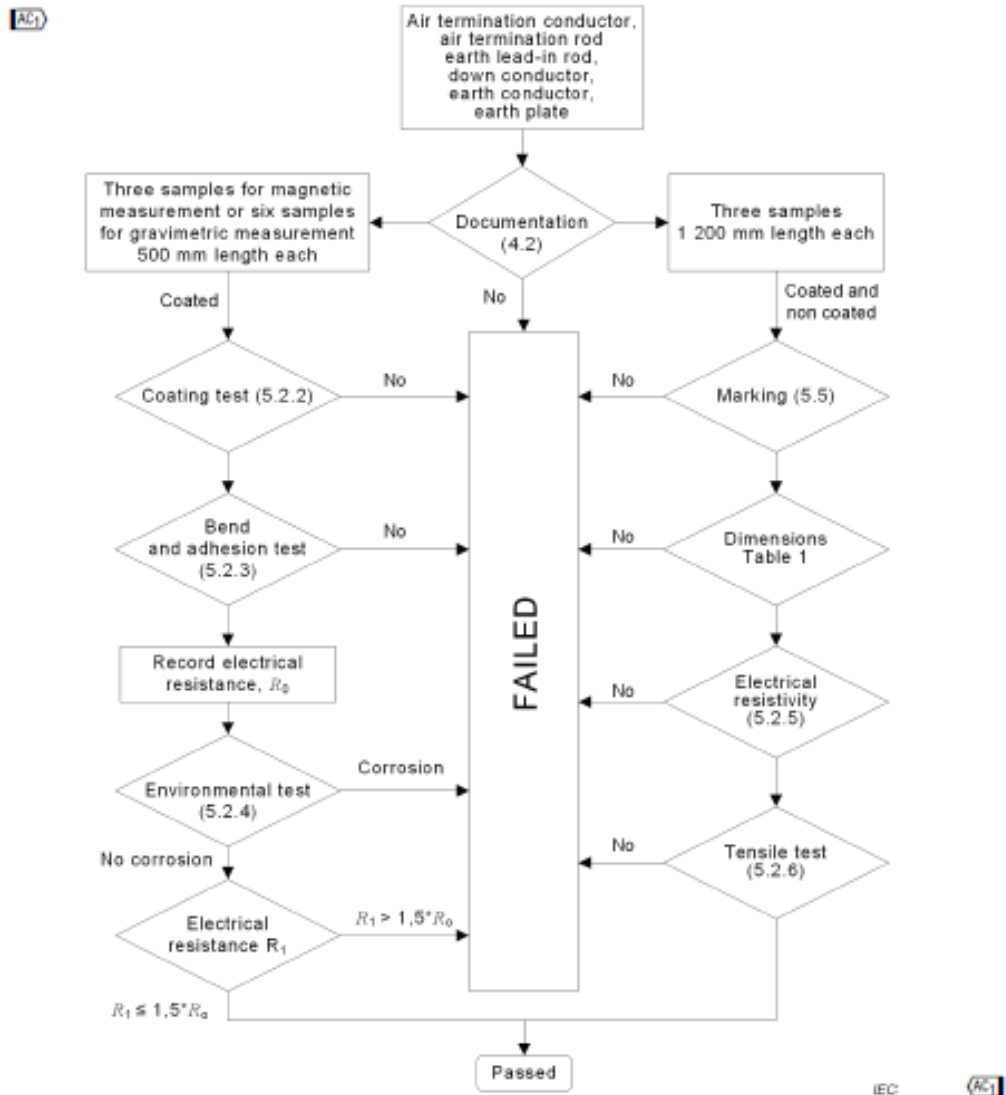
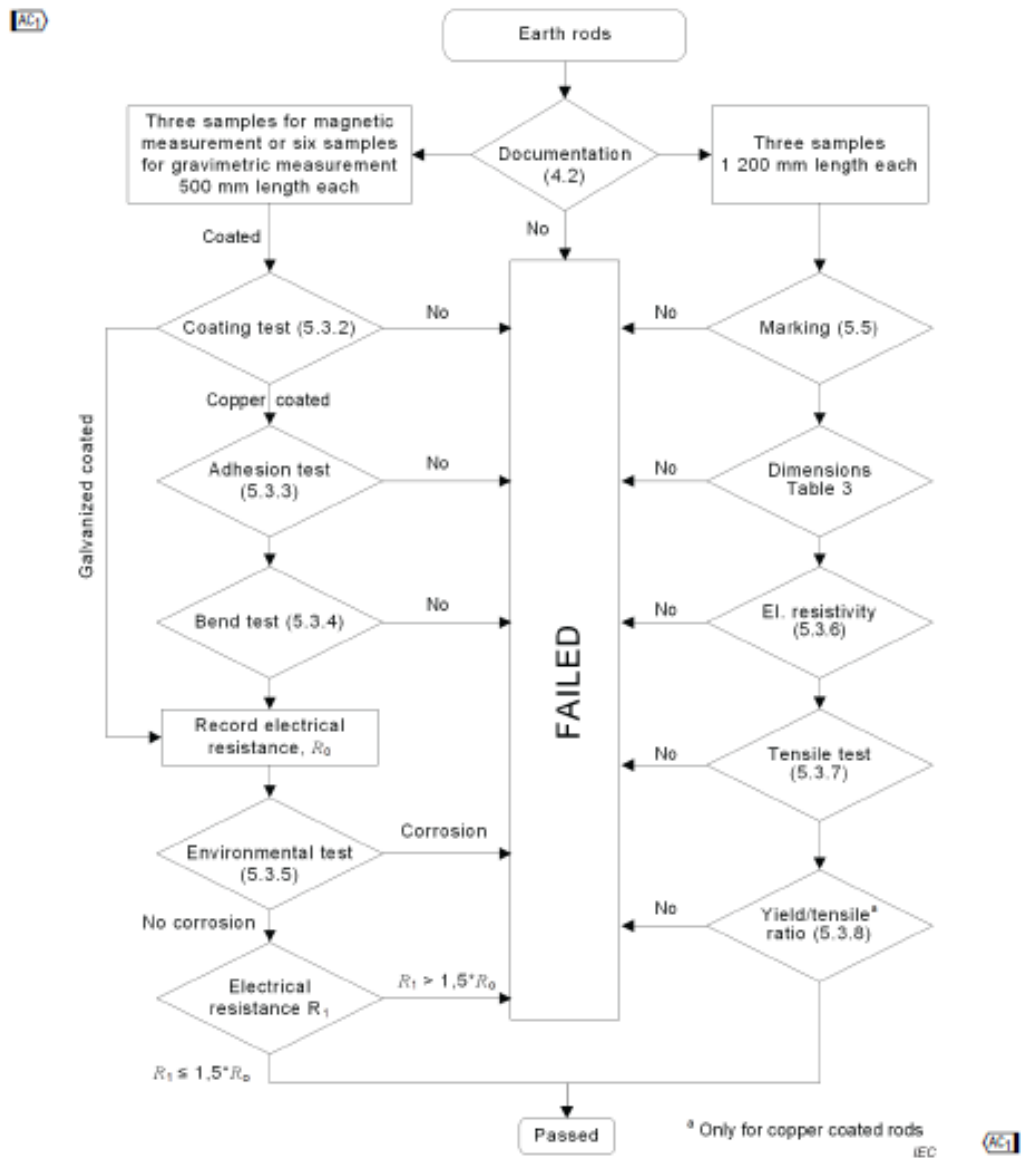

**Figure E.1 – Flow chart of tests for air-termination conductors, air-termination rods, earth lead-in rods, down-conductors, earth conductors and earth plates**



**Annex F**  
(normative)

**Flow chart of tests for earth rods**

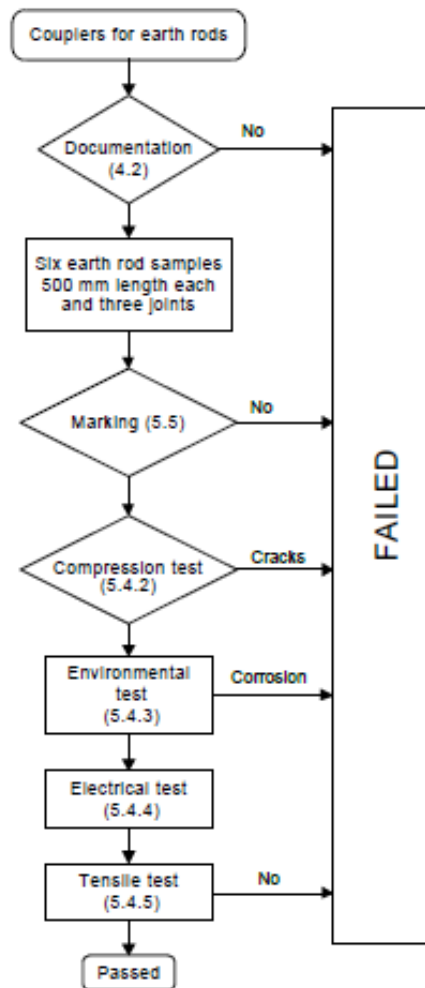

**Figure F.1 – Flow chart of tests for earth rods**

**Annex G**  
(normative)**Flow chart of tests of couplers for earth rods**

IEC

**Figure G.1 – Flow chart of tests of couplers for earth rods**



**Statement of Measurement Uncertainty**

The Test Report shall include a statement concerning the uncertainty of the measurement systems used for the tests conducted when it is required by the standard, client or other authorities.

In such cases, the table below is to be used for reporting U of M.

This page may be removed from the final Test Report when not required. See also clause 4.8 in OD 2020 for more details.

<b>Clause #</b>	<b>Parameter/ Measurement / test method</b>	<b>Requirement % or k</b>	<b>Calculated U of M*</b>

\*Note: Calculations leading to the reported value are on file with the NCB

**Product:** air-termination rods

**Type Designation:** KYC-LAT

<b>Test Equipment list</b> ( Sichuan Accuracy)					
Instrument Number	Instrument Name	Technical Parameters	Model Type	Last Cal. Date	Next Cal. Date
ATA228	Vernier caliper	0-200mm	0-200mm	2022/09/21	2023/09/20
ATA204	steel tap	0~5m	5m	2022/09/27	2023/09/26
ATA149	DC microhm meter	1 $\mu\Omega$ ~ 2M $\Omega$	YD2511A	2022/08/11	2023/08/10
ATA209	Thermal imaging system	-20°C ~ +800°C	Tix580	2022/11/02	2023/11/01
<b>Test Equipment list</b> ( Chengdu Hanzhun)					
1	Thickness tester	0.1um	TT260	2022.11.11	2023.11.10
2	Material tensile testing machine	grade 0.5	BJ16024	2022.11.11	2023.11.10

Product: air-termination rods

Type Designation: KYC-LAT



Figure 1



Figure 2

Product: air-termination rods  
Type Designation: KYC-LAT

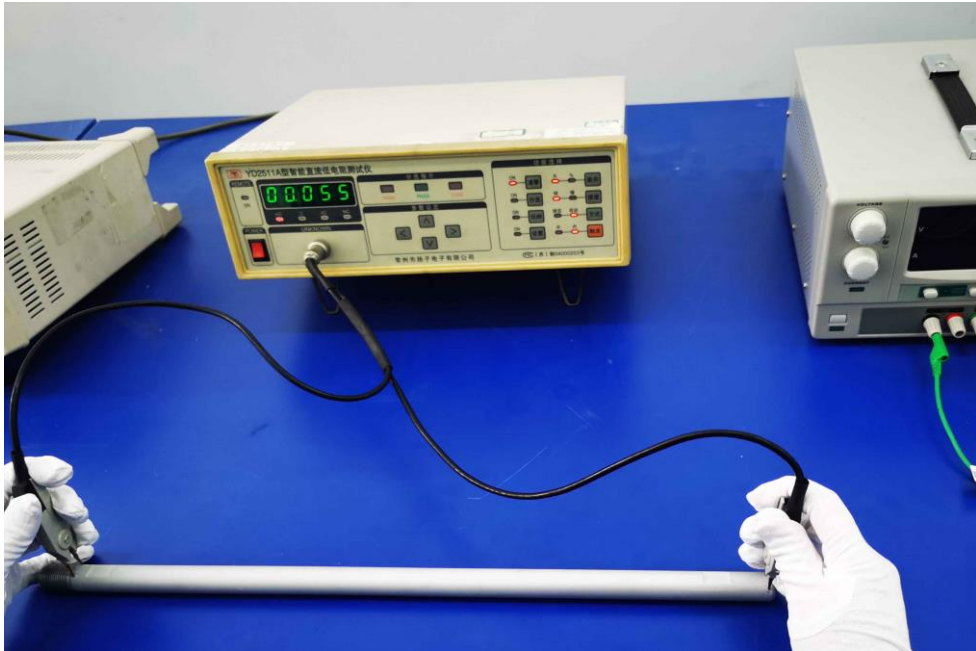

Figure 3

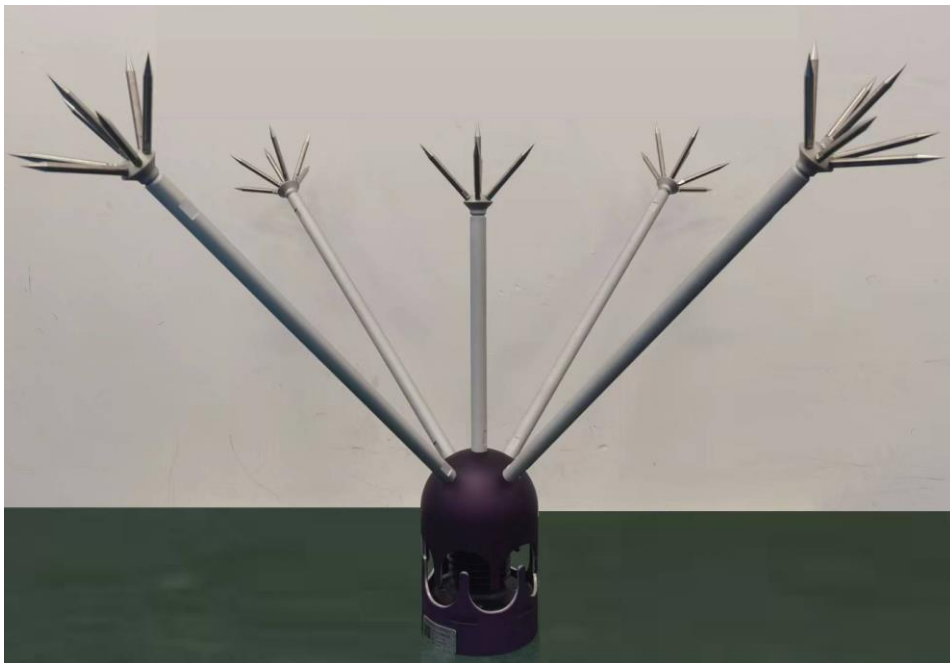

Figure 4